

FS Newsletter

Friday 19th April 2024

Communication and Language

Stories and books we have enjoyed this week!

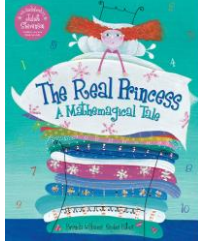
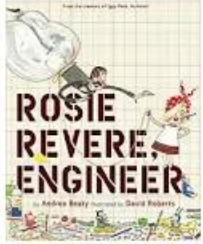
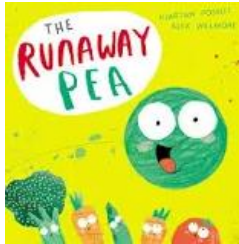

Literacy

In Literacy our story was The Runaway Pea. After writing about a character and thinking about the different settings in the book, the children went on an adventure to extend the story. The runaway pea found a different place to land and then later met another fruit or vegetable growing in the compost heap.

We have now started phase 4 in phonics, this week we have been learning the tricky words: some, come, do, so, there, have, like, one, little, said, out.

At home you could try:

- Reading with your child.
- Collecting 10 sticks to make a bundle of 10 and then extra sticks to make representations of numbers between 10 and 20
- Use the pictures attached to write the words.
- Find out your address, maybe you could find your road on a map

Notes for Parents

It has been wonderful to welcome the children back after the Easter break. Attached below is a Wellie Wednesday rota, as we are hoping to go to the lakes and continue our campfire cooking. However this may be subject to change if we do not have enough volunteers.

Please check to see when it is your child's 'Be the Teacher'.

Looking forward to the week ahead!

The Foundation Team

Maths

In Maths this week we have been looking at numbers to 20. We have thought about their composition for example 11 is 1 ten and 1 more by using numicon, tens frames, cubes and bead strings.

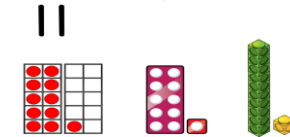

Understanding the World

This week we have been excited about growing things! The children have enjoyed sowing seeds in the garden and have been thinking about the things plants need to grow. We set up experiments to see what happens to a pea and potato if they are just left.

The children have enjoyed looking at a map of Thatcham. There was much excitement when we found our school and some of the roads we live in!

In PSED we have been thinking about resilience, perseverance and practicing to reach our goals. We talked about facing challenges and how we feel when things go wrong.

Expressive Arts and Design

The children have continued to express their ideas through role-play, modelling, music and drawing.

Please get your child to practise sounding out the words to these pictures and writing them. Encourage them to blend the words they have written to check they have all the sounds.

ur



Blank writing area with a grid for the word 'surfer'.

ur



Blank writing area with a grid for the word 'church'.

oi



Blank writing area with a grid for the word 'one'.

oi

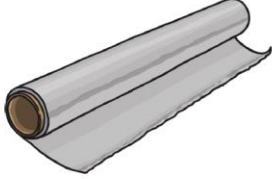

Blank writing area with a grid for the word 'roll'.

car

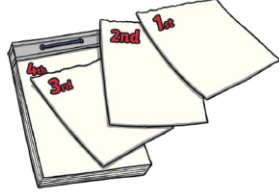

Blank writing area with a grid for the word 'card'.

car



Blank writing area with a grid for the word 'car'.

air



Blank writing area with a grid for the word 'air'.

air



Blank writing area with a grid for the word 'air'.

urc



Blank writing area with a grid for the word 'penguin'.

urc



Blank writing area with a grid for the word 'family'.

cr



Blank writing area with a grid for the word 'bridge'.

cr

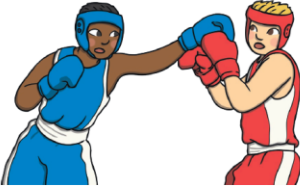

Blank writing area with a grid for the word 'cr'.

Be the Teacher

Date	Child	Date	Child
Friday 19 th April	Salma	Friday 14 th June	Maie
Friday 26 th April	Rex	Friday 21 st June	Charly
Friday 3 rd May	Ossie	Friday 28 th June	Kayden
Friday 10 th May	Harvey	Friday 5 th July	Olivia
Friday 17 th May	Isla-Rose	Friday 12 th July	Imey
Friday 24 th May	Jasmine	Friday 19 ^h July	Maya
Friday 7 th June	Kane		

Proposed Wellie Wednesday Rota

Date	Activity
Wednesday 24 th April	Lakes trip
Wednesday 1 st May	Campfire cooking
Wednesday 8 th May	Farm Trip
Wednesday 15 th May	Field
Wednesday 22 nd May	Lakes trip
Wednesday 5 th June	Campfire cooking
Wednesday 12 th June	Field
Wednesday 19 th June	Lakes trip
Wednesday 26 th June	Campfire cooking
Wednesday 3 rd July	Field
Wednesday 10 th July	Lakes trip
Wednesday 17 th July	Campfire cooking

NB – may be subject to change